



2024

Sensor Setup – DTS Thermocouple Adaptor

CONCEPTUAL REVIEW, BASIC SETUP, BEST PRACTICES

JOHN MOORS

Contents

Introduction	2
Application Notes and Disclaimers	2
General: Measuring Temperature with DTS DAS.....	2
General: Cold Junction Compensation.....	2
General: Direct Thermocouple Connections (No Adapter)	2
Basic Setup for Unipolar Sensors	3
Range and Capacity.....	4
Setup: Thermocouple THA-K-1250	5
Initial EU Calculation	5
Half Bridge.....	5
High and Low Offset Calculation.....	5
Setup: Thermocouple THA-K-400	6
Half Bridge.....	6
High and Low Offset Calculation.....	6
DataPRO Initial EU	7
Wiring	8
Alternative Wiring: TDAS PRO SIM and TDAS G5	9
DTS Specific Data Acquisition System Notes.....	10
Need More Help?	11

Introduction

Thermocouples, like many “absolute” or unipolar sensors, are perhaps intuitive in their operation but not necessarily intuitive in their connection and operation with a typical DAS. Therefore, this article will explain the technical background behind certain DAS software settings as well as give specific steps for configuring the sensors with your system.

For a more comprehensive breakdown of **Bipolar vs. Unipolar Sensors**, click here for the article:

Further Reading 

Application Notes and Disclaimers

This configuration information is applicable for DTS SLICE and G5 systems when 5Vdc excitation is selected. For TDAS PRO SIM, see “Alternative Wiring” later in this document.

For SLICE and G5, software will “flag” the range of the adapter. This is due to the expectation of a bi-polar sensor. Software will reflect a maximum range of approximately half the requested output range. This is expected. The full range of the sensor is not affected. The THA is a unipolar output.

General: Measuring Temperature with DTS DAS

We have a full summary on measuring temperature with DTS Data Acquisition Systems, which describes the basics of each method and links to more comprehensive articles.

To see our summary on **Measuring Temperature with DTS DAS** and all related articles, click here:

Further Reading 

General: Cold Junction Compensation

A thermocouple adaptor compensates for the Cold Junction, or parasitic effects of the electronics connected directly to a thermocouple.

For a more comprehensive breakdown on **Cold Junction Compensation**, click here for the article:

Further Reading 

General: Direct Thermocouple Connections (No Adapter)

To quantify the estimated accuracy of temperature measurements using Type-K thermocouple wire soldered directly to the SLICE6 Air sensor input connector, we ran a series of tests and published the results.

To see the results of a **SLICE6 Air Thermocouple** test DTS conducted, click here for our online test:

Test Report 

Basic Setup for Unipolar Sensors

For a unipolar or “absolute” sensor, its output signal will typically begin at or near zero then increase toward its maximum reading. For example, a type K Thermocouple with DTS supplied adapter runs from 0°C to 1250°C. It does not have an evenly split negative and positive range.



OFFSET and ZEROING: A bipolar sensor’s Engineering Units Halfway Point (HP) will be approximately 0V. No sensor is perfect, so we generally want to remove any non-zero offset voltage. However, a unipolar sensor reading absolute temperature or pressure will report voltage that represents the absolute measurement value, and we do not want to remove this voltage from the readings.

- **Offset: Do Not Remove**
- **Zero Type: Absolute Zero**

EU_i

Initial EU: The Halfway Point (HP) is still halfway through our signal range, but as our unipolar range is not centered at zero EU, we need to find the actual halfway value. By identifying the midpoint of the useful range of our unipolar sensor (for example, 0°C to 1250°C), we can estimate the Initial EU (1250/2 which is 625°C). This number is also the starting point for our sensor calibration (see below). Any Lower Limit (negative range) is added afterwards to ensure we are properly centered.

- **Initial EU:** $\left(\frac{1}{2} \text{Sensor Range}\right) + \text{Lower Limit}$



For DataPRO users, make sure to read the DataPRO | Initial EU section later in this document



CALIBRATE: Since our temperature sensor is likely reporting an ambient value, for example room temperature 22°C, we can calibrate the sensor by fine tuning the Initial EU to agree with a calibrated thermometer. If we used that 625°C estimate, we could begin there then adjust it as needed to match a known ambient reading. A more robust method would be to check the readings over a wider range by using a thermocouple simulator readily available from various suppliers.

- **Calibrate Using: Initial EU**

Omega and other suppliers sell Thermocouple Simulators:

Site Link





SENSITIVITY: Here we'll still use the Sensitivity from the sensor's calibration sheet, relying on the Initial EU precise adjustments for the calibration.

- **Sensitivity:** Use Calibration Sheet Data

Differential Signal of a Unipolar Sensor within the Common Mode Range

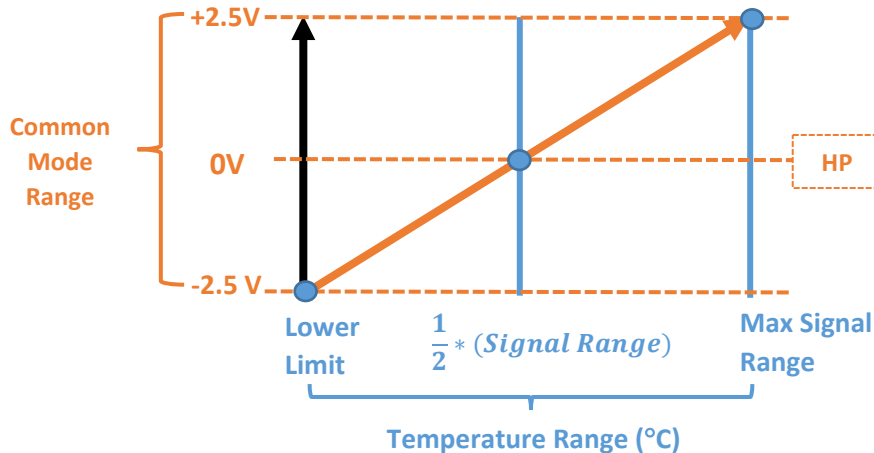

Range and Capacity

In the following pages, one of the numbers is the range of the sensor. This can sometimes be called Capacity or Sensor Max Range.

These terms are sometimes used interchangeably and can be confusing. When setting up your sensor settings the field you will use will depend on the software you are using. For example, in SLICEWare you will put in this number into the "Desired Range" field. In DataPRO this is referred to as Capacity, and in newer versions this was updated to "Sensor Max Range" to avoid confusion.

Also, while the below shows direct equations for setting up those particular models, if you are using a different unit you can use a general rule of ~half the total absolute value of the range. This means if the thermocouple adapter's total absolute range is 1,000, then in the sensor settings in the software using roughly 500 should work. This is assuming the make and model is supported by our hardware. Examples of that equation are in the following pages.

Setup: Thermocouple THA-K-1250

This has a Sensor Range of 0°C to 1250°C, with no Lower Limit to add on to our equation. To set this up, we apply that equation described in the previous section.

Initial EU Calculation

- Initial EU: $\frac{1}{2}(\text{Sensor Range}) + \text{Lower Limit}$
- Initial EU: $\frac{1}{2}(1250^{\circ}\text{C}) + 0$
- **Initial EU: 625°C**

Note: Range is selected to use the appropriate gain and will result in the widest range of measurement possible.

Half Bridge

For this 3 Wire Connection where we are only receiving a Negative Signal from the adaptor, we'll need to use Half Bridge mode in our settings. This uses the 2.5 V from the +EXC to take place of the +SIG we are not receiving.

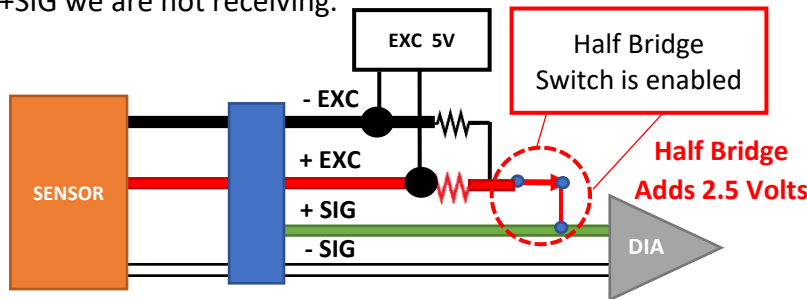

SENSOR SETTINGS	
•	Range: 600
•	Initial EU: 625 (can fine adjust)
•	Excitation: 5V or 10V
•	Bridge: Half
•	Proportional: No
•	Invert: Yes
•	Remove Offset: No
•	Zero: Absolute
•	Use Shunt: No
•	Sensitivity: See Cal Sheet
•	Offset Low: 2350 mV
•	Offset High: 2450 mV

High and Low Offset Calculation

Set the software High/Low offset limits near the expected starting point of the sensor. For example, at 22°C our THA-K-1250 reports ~88mV.

- Offset Middle: $\text{Max} - (\text{mV at Starting Point})$
- Offset Middle: $(2500 \text{ mV}) - (88 \text{ mV})$
- Offset Middle: **2420 mV**
- Offset Low: **2350 mV**
- Offset High: **2450 mV**

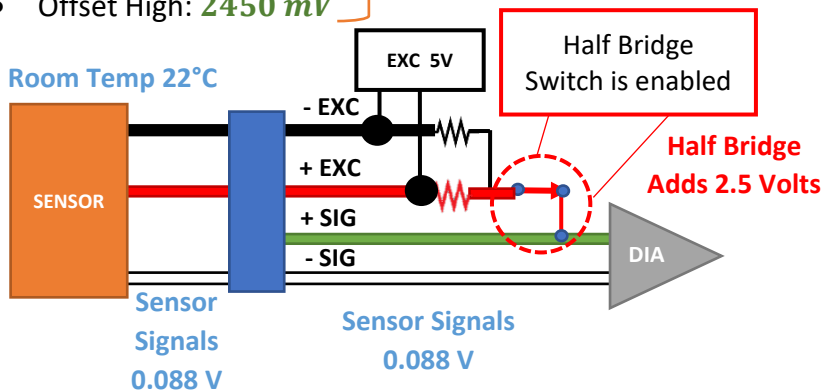

For DataPRO users, make sure to read the **DataPRO | Initial EU** section later in this document

Setup: Thermocouple THA-K-400

This has a Sensor Range of 500°C, with a -100°C Lower Limit to add on to our equation. To set this up, we apply that equation described in the previous section.

- Initial EU: $\frac{1}{2}(\text{Sensor Range}) + \text{Lower Limit}$
- Initial EU: $\frac{1}{2}(500^\circ\text{C}) + (-100^\circ\text{C})$
- **Initial EU: 150°C**

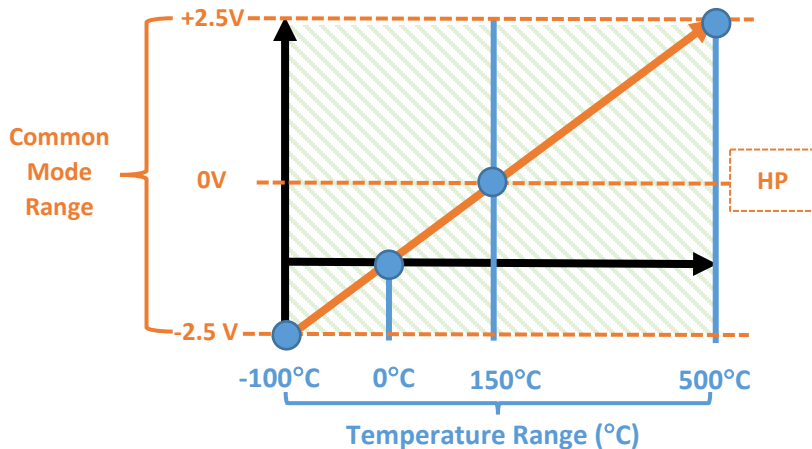

Note: Range is selected to use the appropriate gain and will result in the widest range of measurement possible.

SENSOR SETTINGS	
• Range: 200	
• Initial EU: 150 (can fine adjust)	
• Excitation: 5V or 10V	
• Bridge: Half	
• Proportional: No	
• Invert: Yes	
• Remove Offset: No	
• Zero: Absolute	
• Use Shunt: No	
• Sensitivity: See Cal Sheet	
• Offset Low: 1200 mV	
• Offset High: 1300 mV	

Half Bridge

For this 3 Wire Connection where we are only receiving a Negative Signal from the adaptor, we'll need to use Half Bridge mode in our settings. This uses the 2.5 V from the +EXC to take place of the +SIG we are not receiving.

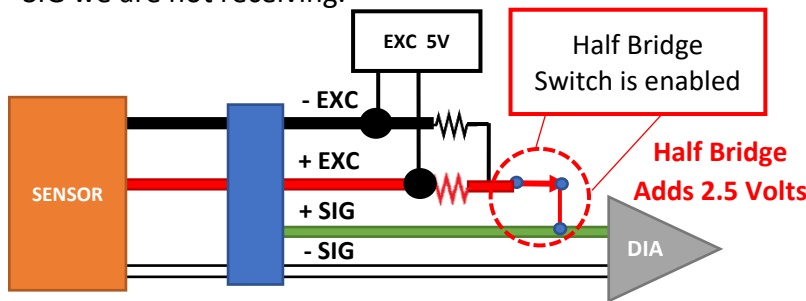

High and Low Offset Calculation

Set the software High/Low offset limits near the expected starting point of the sensor. For example, at 22°C our THA-K-400 reports ~1220mV.

Room Temp 22°C

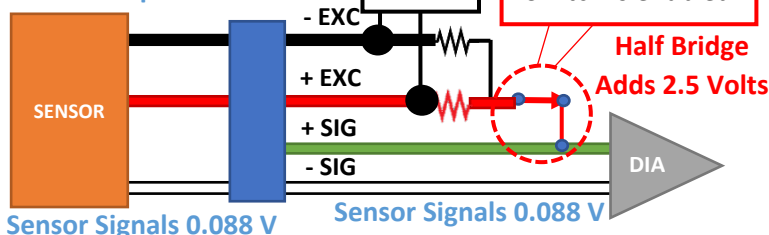

- Offset Middle: $Max - (\text{Starting Pt})$
- Offset Middle: $(2500\text{ mV}) - (1200\text{ mV})$
- Offset Middle: **1280 mV**
- Offset Low: **1200 mV**
- Offset High: **1300 mV**



For DataPRO users, make sure to read the **DataPRO | Initial EU** section later in this document



DataPRO | Initial EU

Depending on your version of DataPRO, you should ensure that the Initial EU you set in the Sensor Settings also auto-populates in Test Setups where that sensor is assigned.

In your sensor settings, under the Calibration Section of your thermocouple adapter, this is the field being referenced:

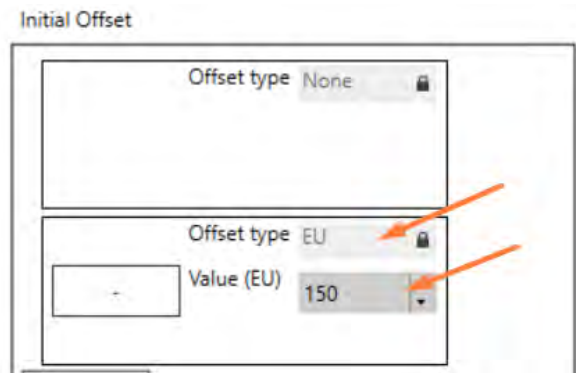

Once you have created a Test Setup and assigned all channels, navigate to the Parameters section and make sure that your Initial Offset is set to EU.

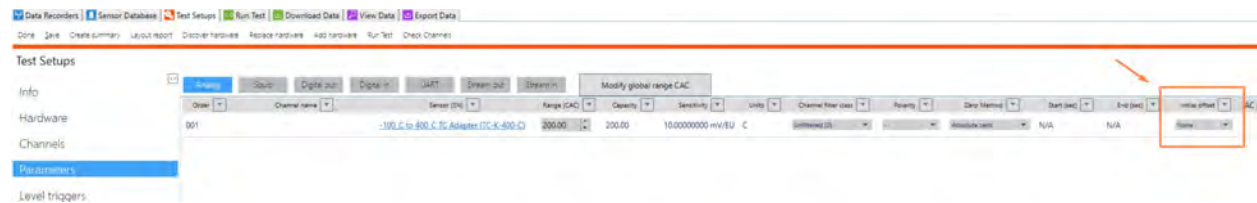

If you are not able to select “EU” from the dropdown, instead click the dropdown itself and type “e” which should then choose “EU” for you. Make sure to save after these changes.

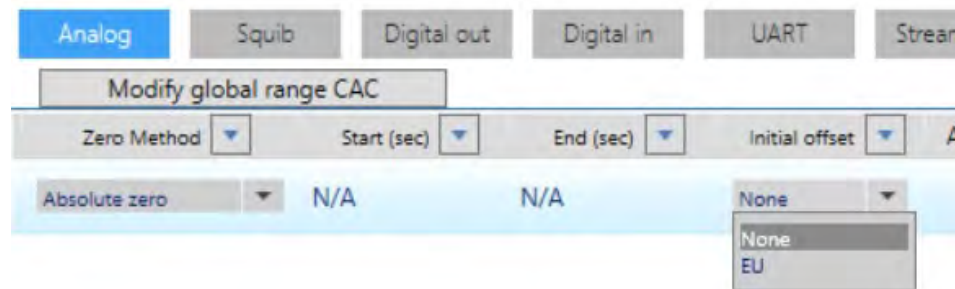

Wiring

- Consult your documentation for the corresponding pin numbers of the sensor input connectors
- Shielding is required for improved performance. Connect the adapters shield wire to the ground connection. Any ground (case when available) is required for low level (mV output) transducers
- Set the software HIGH/LOW offset limits to values near the expected starting output of the sensor. The output of the THA-400 and THA-1250 are 1220mV and 88mV respectively at 22°C
- THA-K-400 at 22°C is ~1220mV (2500-1220=1280mV offset at ambient)
- THA-K-1250 at 22°C is ~88mV (2500-88=2420mV offset at ambient)

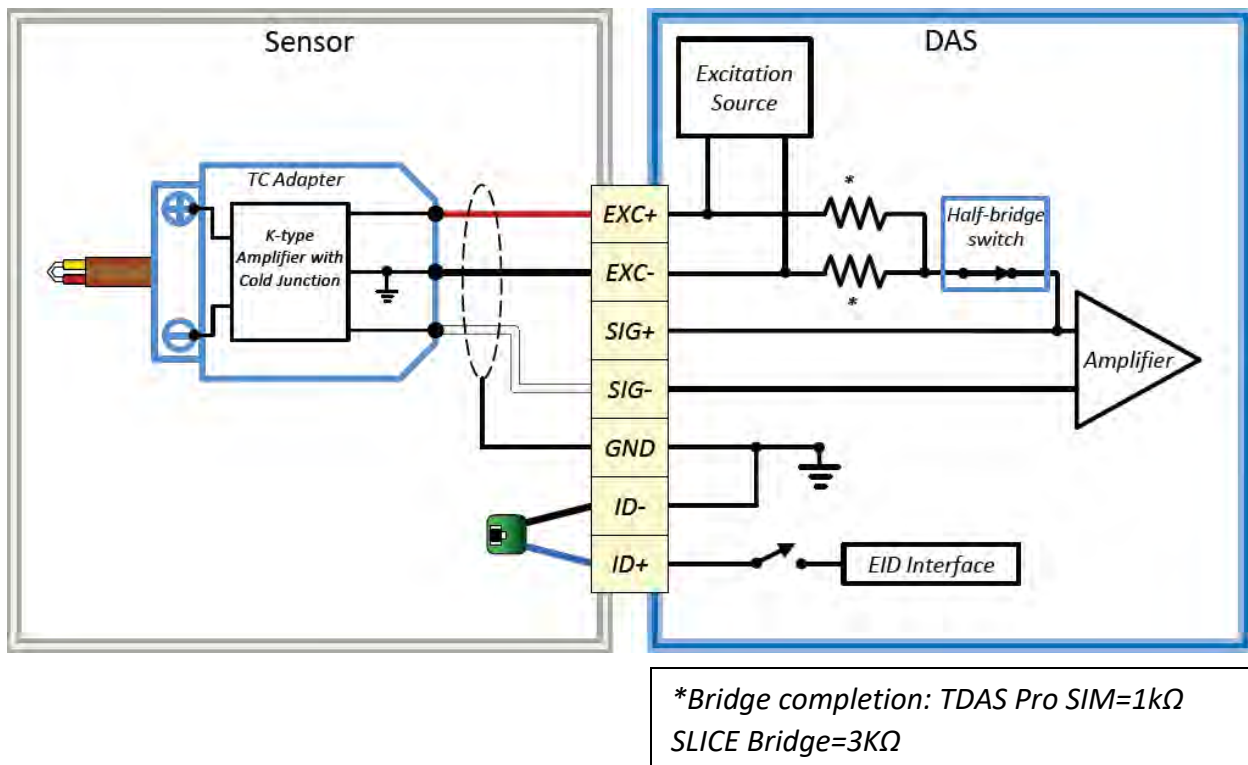

Alternative Wiring: TDAS PRO SIM and TDAS G5

Full setup breakdowns for different DAS are below.

Alternative Wiring: TDAS PRO SIM

- The +/-5V input of the TDAS PRO SIM allows SIG+ to be referenced to ground. This allows the SIM to correctly measure the full range of the Thermocouple.
- Sensor settings for the SIM are different from SLICE and G5 settings. Adjust the SIM SIF as follows:
 - Initial EU Value is 0.0
 - Set SENSOR TYPE to Full Bridge

Alternative Wiring: TDAS G5

- SIG- must have no contact
 - The G5 places a 2.5V reference on the SIG- input
- Sensor settings for the G5 are different from SLICE and SIM. Adjust the G5 SIF as follows:
 - Set invert to NO

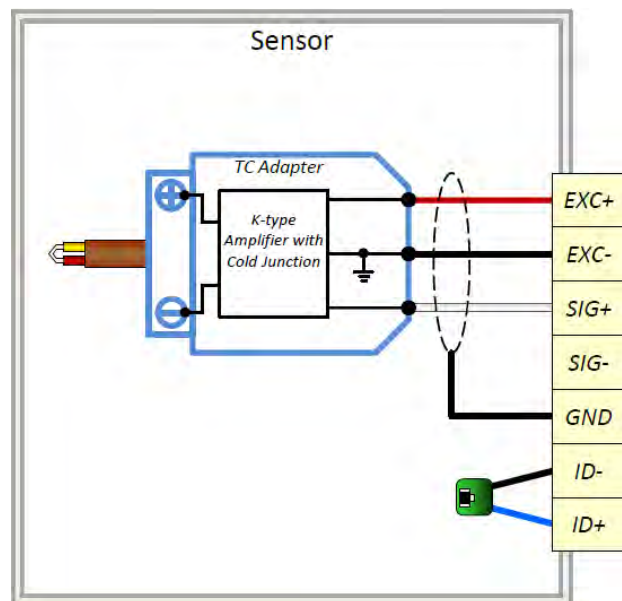
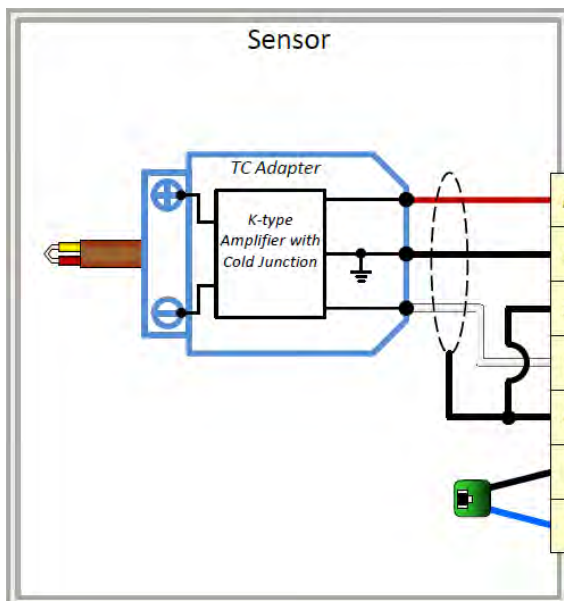

DTS Specific Data Acquisition System Notes

- Please note the specific requirements of your system. The Linear Range limit is the output of the THA within the common mode input range of the DTS DAS. The THA is tested with all DTS hardware and will work outside the linear range to the THA's specified range. Reduced accuracy may occur when operating outside the ranges listed below.
- If you need specific connector information, please refer to your owner's manual. If additional information is needed, provide a DTS hardware serial number when contacting support.
- When requesting assistance, provide the make and model of your sensor and include the datasheet when available.

Product Family	Input Range Limitations	Software Notes
SLICE NANO/Micro	Linear Range: THA-K-400: -90°C to 390°C THA-K-1200: 25°C to 1225°C	Proportional to Excitation = No Bridge Mode = Half Remove Offset = No Invert = Yes
SLICE Pro	None	Proportional to Excitation = No Bridge Mode = Half Remove Offset = No Invert = Yes
TDAS Pro SIM	None	Proportional to Excitation = No Bridge Mode = Full Remove Offset = No Invert = Yes Initial EU Value = 0.0
TDAS G5	Linear Range: THA-K-400: -50°C to 350°C THA-K-1200: 125°C to 1225°C	Proportional to Excitation = No Bridge Mode = Half Remove Offset = No Invert = Yes

Need More Help?

The online Help Center has additional resources to help get you up and running!

We have support engineers in multiple time zones with various backgrounds who can assist. Registering creates a profile for your setup and keeps your records/requests organized going forward. You don't need to be registered to submit a Help Ticket, but it keeps all your info in one place.

Here's how to get started. **The buttons below will take you directly to the specific web pages.**

1. Head to our Help Center main page for support resources.
2. Register as a new user.
3. Submit a Help Ticket. You can CC members of your organization, attach files, and add any helpful links.
4. Feel free at any time to check out our Knowledge Base. It has articles, videos, and breakdowns of our hardware and software, as well as general information and best practices. We're frequently updating this library to keep users informed.
5. Our Video Library has Webinar Recordings, Product Overviews, and Training. If you'd like to join a future webinar, let us know!

We are looking forward to supporting your needs!

